

A  
FL  
C  
D  
E  
F  
G  
H  
I  
J  
K  
L  
M  
N  
O  
P

# SECTION **FL**

## FUEL SYSTEM

### CONTENTS

<b>PRECAUTION</b> .....	2	<b>EVAP CANISTER</b> .....	15
<b>PRECAUTIONS</b> .....	2	Exploded View .....	15
Precaution for Supplemental Restraint System (SRS) "AIR BAG" and "SEAT BELT PRE-TENSIONER" .....	2	Removal and Installation .....	15
General Precaution .....	2	Inspection .....	16
<b>PREPARATION</b> .....	3	<b>EVAP CANISTER FILTER</b> .....	17
<b>PREPARATION</b> .....	3	Exploded View .....	17
Special Service Tool .....	3	Removal and Installation .....	17
Commercial Service Tool .....	3	<b>EVAP CANISTER VENT CONTROL VALVE</b> ...	18
<b>PERIODIC MAINTENANCE</b> .....	4	Exploded View .....	18
<b>FUEL SYSTEM</b> .....	4	Removal and Installation .....	18
Inspection .....	4	<b>EVAP CONTROL SYSTEM PRESSURE SENSOR</b> .....	19
Quick Connector .....	4	Exploded View .....	19
<b>REMOVAL AND INSTALLATION</b> .....	5	Removal and Installation .....	19
<b>FUEL LEVEL SENSOR UNIT, FUEL FILTER AND FUEL PUMP ASSEMBLY</b> .....	5	<b>DISASSEMBLY AND ASSEMBLY</b> .....	20
Exploded View .....	5	<b>FUEL LEVEL SENSOR UNIT</b> .....	20
Removal and Installation .....	5	Exploded View .....	20
Inspection .....	9	Disassembly and Assembly .....	20
<b>FUEL TANK</b> .....	10	<b>SERVICE DATA AND SPECIFICATIONS (SDS)</b> .....	22
Exploded View .....	10	<b>SERVICE DATA AND SPECIFICATIONS (SDS)</b> .....	22
Removal and Installation .....	10	Fuel Tank .....	22
Inspection .....	14		

# PRECAUTIONS

< PRECAUTION >

## PRECAUTION

### PRECAUTIONS

#### Precaution for Supplemental Restraint System (SRS) "AIR BAG" and "SEAT BELT PRE-TENSIONER"

INFOID:000000011934764

The Supplemental Restraint System such as "AIR BAG" and "SEAT BELT PRE-TENSIONER", used along with a front seat belt, helps to reduce the risk or severity of injury to the driver and front passenger for certain types of collision. Information necessary to service the system safely is included in the SR and SB section of this Service Manual.

#### **WARNING:**

- To avoid rendering the SRS inoperative, which could increase the risk of personal injury or death in the event of a collision which would result in air bag inflation, all maintenance must be performed by an authorized NISSAN/INFINITI dealer.
- Improper maintenance, including incorrect removal and installation of the SRS, can lead to personal injury caused by unintentional activation of the system. For removal of Spiral Cable and Air Bag Module, see the SR section.
- Do not use electrical test equipment on any circuit related to the SRS unless instructed to in this Service Manual. SRS wiring harnesses can be identified by yellow and/or orange harnesses or harness connectors.

#### PRECAUTIONS WHEN USING POWER TOOLS (AIR OR ELECTRIC) AND HAMMERS

#### **WARNING:**

- When working near the Airbag Diagnosis Sensor Unit or other Airbag System sensors with the Ignition ON or engine running, DO NOT use air or electric power tools or strike near the sensor(s) with a hammer. Heavy vibration could activate the sensor(s) and deploy the air bag(s), possibly causing serious injury.
- When using air or electric power tools or hammers, always switch the Ignition OFF, disconnect the battery and wait at least three minutes before performing any service.

#### General Precaution

INFOID:000000011934765

#### **WARNING:**

When replacing fuel line parts, be sure to observe the following:

- Put a "CAUTION: FLAMMABLE" sign in the workshop.
- Be sure to work in a well ventilated area and furnish workshop with a CO<sub>2</sub> fire extinguisher.
- Do not smoke while servicing fuel system. Keep open flames and sparks away from the work area.

#### **CAUTION:**

- Use gasoline required by the regulations for octane number. Refer to [GI-27, "Fuel"](#).
- Before removing fuel line parts, perform the following procedures:
  - Put drained fuel in an explosion-proof container and put the lid on securely. Keep the container in safe area.
  - Release fuel pressure from the fuel lines. Refer to [EC-168, "Work Procedure"](#).
  - Disconnect the battery cable from the negative terminal.
  - Always replace O-ringS and clamps with new ones.
  - Do not kink or twist tubes when they are being installed.
  - Do not tighten hose clamps excessively to avoid damaging hoses.
  - After installing tubes, check that there are no fuel leaks at connections in the following steps.
  - Apply fuel pressure to fuel lines by turning ignition switch "ON" (with engine stopped). Then check for fuel leaks at connections.
  - Start engine and rev it up and check for fuel leaks at connections.
- Use only a genuine NISSAN fuel filler cap as a replacement. If an incorrect fuel filler cap is used, the "MIL" may come on.

# PREPARATION

< PREPARATION >

## PREPARATION

### PREPARATION

#### Special Service Tool

INFOID:000000011934766

A

FL

The actual shape of the tools may differ from those illustrated here.

Tool number (TechMate No.) Tool name	Description
KV101207S0 ( — ) Unified fuel lock ring wrench	Removing and installing fuel tank lock ring
KV991J0090 (J-46214) Fuel tank lock ring wrench	

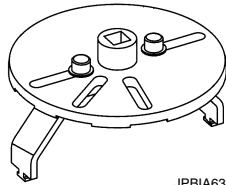

JPBIA6384ZZ

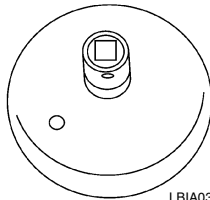

LBIA0353E

C

D

E

F

G

H

#### Commercial Service Tool

INFOID:000000011934767

Tool name	Description
Power tool	Loosening nuts, screws and bolts



PIIB1407E

I

J

K

L

M

N

O

P

# FUEL SYSTEM

< PERIODIC MAINTENANCE >

## PERIODIC MAINTENANCE

### FUEL SYSTEM

#### Inspection

INFOID:0000000011934768

Inspect fuel lines, fuel filler cap, and fuel tank for improper attachment, leaks, cracks, damage, loose connections, chafing or deterioration.

- (A) : Engine
- (B) : Fuel line
- (C) : Fuel tank

If necessary, repair or replace damaged parts.

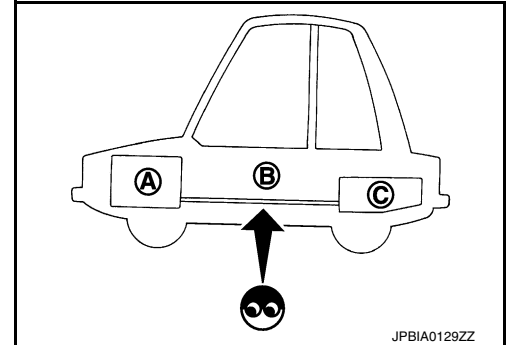

#### Quick Connector

INFOID:0000000011934769

#### CAUTION:

- After connecting fuel tube quick connectors, check that quick connectors are secure.
- Ensure that connector and resin tube never contact any adjacent parts.
- Quick connector (1) can be disconnected when the tabs (F) are depressed completely. Do not twist it more than necessary.

- (B) : Connection (cross-section)
- (D) : To under floor fuel line
- (E) : To fuel tank
- (G) : Disconnection

- Do not use any tools to disconnect quick connector.
- Keep resin tube (C) away from heat. Be especially careful when welding near the resin tube.
- Prevent acid liquid such as battery electrolyte, etc., from getting on resin tube.
- Do not bend or twist resin tube during installation and disconnection.
- Do not remove the remaining retainer (2) from hard tube (or the equivalent) (A) except when resin tube or retainer is replaced.
- When resin tube or hard tube (or the equivalent) is replaced, also replace retainer with new one.

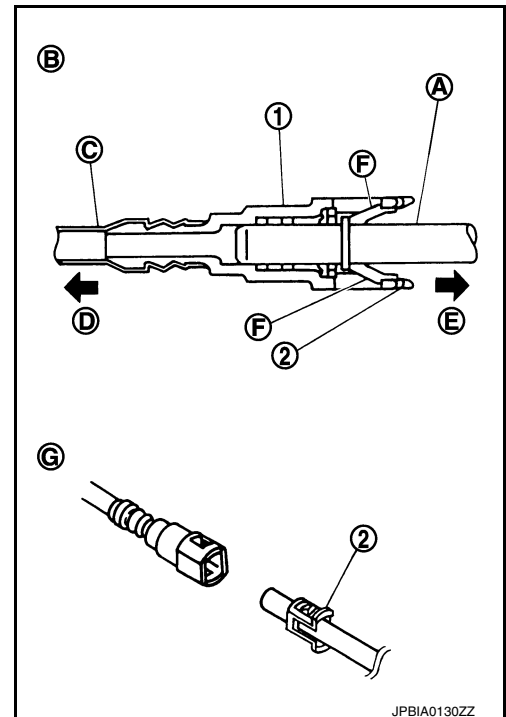

- To keep the connecting portions clean and to avoid damage and foreign materials, cover them completely with plastic bags (A) or something similar.

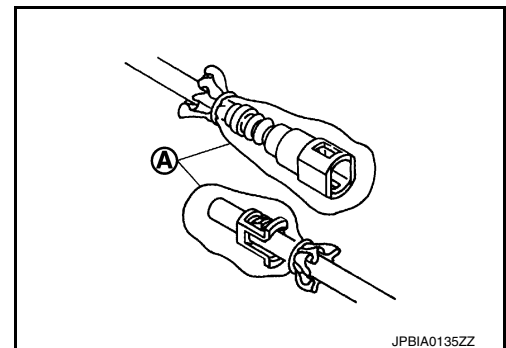

# FUEL LEVEL SENSOR UNIT, FUEL FILTER AND FUEL PUMP ASSEMBLY

< REMOVAL AND INSTALLATION >

## REMOVAL AND INSTALLATION

### FUEL LEVEL SENSOR UNIT, FUEL FILTER AND FUEL PUMP ASSEMBLY

Exploded View

INFOID:0000000011934770

A

FL

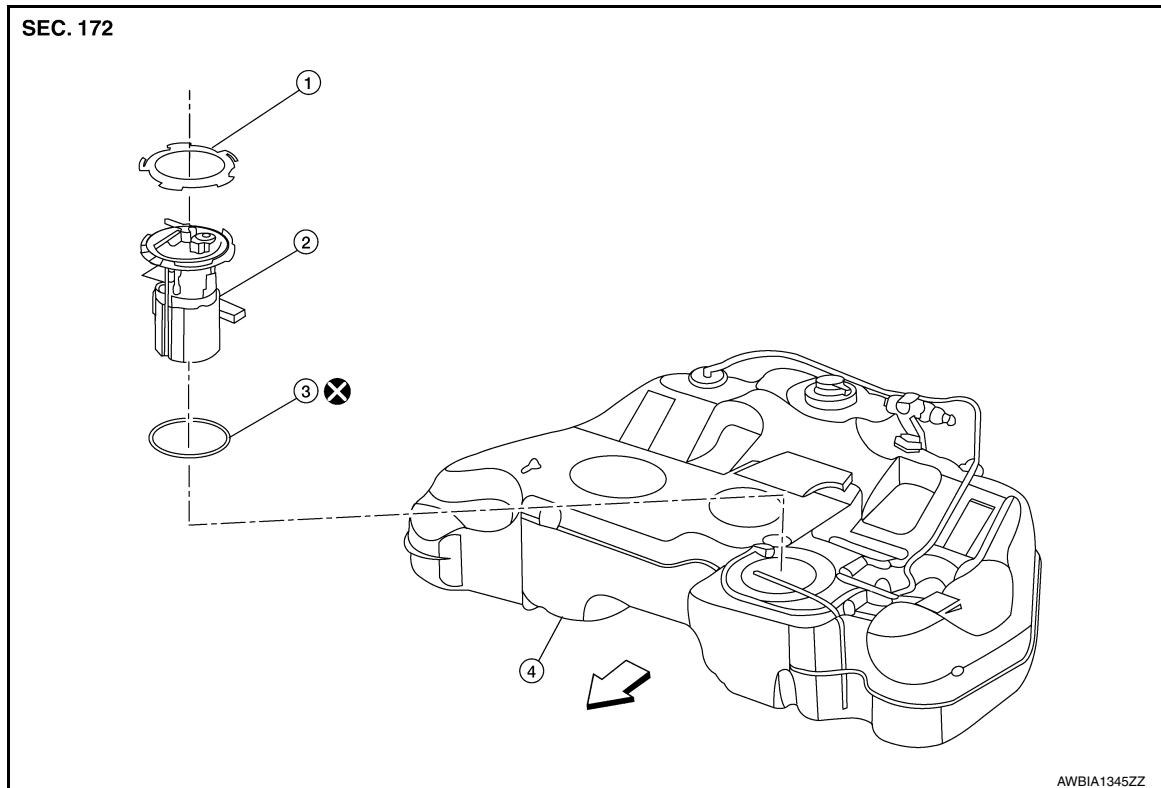

1. Lock ring
  2. Fuel level sensor unit, fuel filter and fuel pump assembly
  3. O-ring
  4. Fuel Tank
- ↔ Front

### Removal and Installation

INFOID:0000000011934771

#### **WARNING:**

Be sure to read "General Precaution" before working on the fuel system. Refer to [FL-2, "General Precaution"](#).

#### **NOTE:**

When removing components such as hoses, tubes/lines, etc., cap or plug openings to prevent fluid from spilling.

#### REMOVAL

1. Unscrew the fuel filler cap to release the pressure inside the fuel tank.
2. Release the fuel pressure from the fuel lines. Refer to [EC-168, "Work Procedure"](#).
3. Disconnect the battery negative terminal. Refer to [PG-101, "Exploded View"](#).
4. Remove the rear seat cushion. Refer to [SE-89, "Removal and Installation"](#).

C

D

E

F

G

H

I

J

K

L

M

N

O

P

# FUEL LEVEL SENSOR UNIT, FUEL FILTER AND FUEL PUMP ASSEMBLY

## < REMOVAL AND INSTALLATION >

5. Turn the four retainers (A) 90° in a clockwise direction and remove the fuel pump inspection hole cover.

⇐ :Front

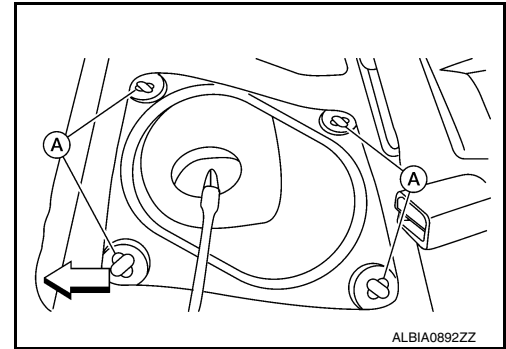

6. Disconnect the harness connector (C), EVAP hose (A), and the fuel feed hose quick connector (B) from the fuel level sensor unit, fuel filter, and fuel pump assembly.

⇐ :Front

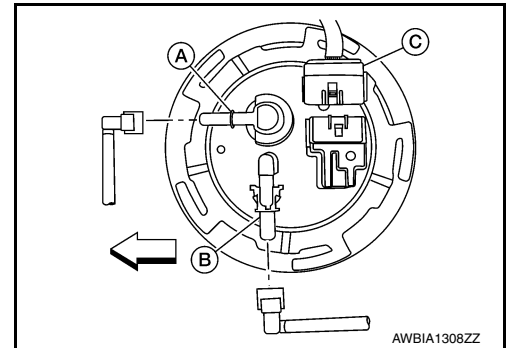

Disconnect the quick connector as follows:

- Hold the sides of connector, press tabs and pull out fuel feed tube.

(A) : Pull

(B) : Push in tabs

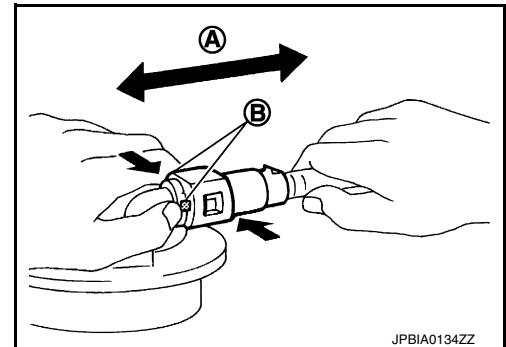

- If quick connector sticks to tube of main fuel level sensor unit, push and pull quick connectors several times until they start to move. Then disconnect them by pulling.

**CAUTION:**

# FUEL LEVEL SENSOR UNIT, FUEL FILTER AND FUEL PUMP ASSEMBLY

## < REMOVAL AND INSTALLATION >

- Quick connector (1) can be disconnected when the tabs (F) are depressed completely. Do not twist it more than necessary.

- (B) : Connection (cross-section)
- (D) : To under floor fuel line
- (E) : To fuel tank
- (G) : Disconnection

- Do not use any tools to disconnect quick connector.
- Keep resin tube (C) away from heat. Be especially careful when welding near the resin tube.
- Prevent acid liquid such as battery electrolyte, etc., from getting on resin tube.
- Do not bend or twist resin tube during installation and disconnection.
- Do not remove the remaining retainer (2) from hard tube (or the equivalent) (A) except when resin tube or retainer is replaced.
- When resin tube or hard tube (or the equivalent) is replaced, also replace retainer with new one.

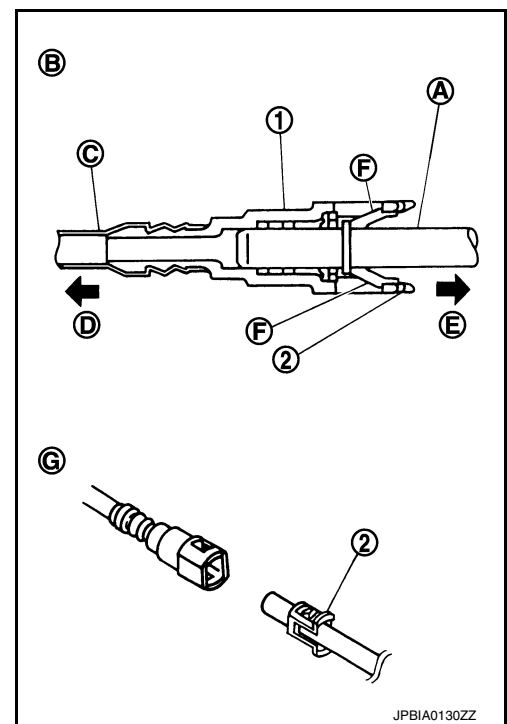

- To keep the connecting portions clean and to avoid damage and foreign materials, cover them completely with plastic bags (A) or something similar.

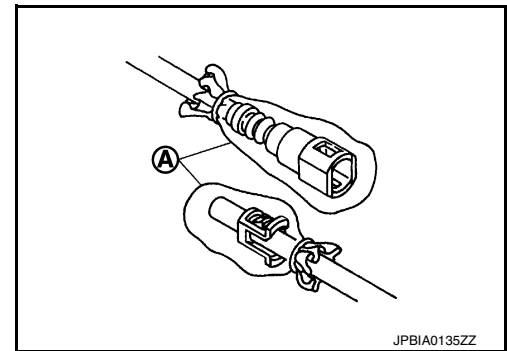

- Remove lock ring from fuel level sensor, fuel filter, and fuel pump assembly.
  - Remove the lock ring using Tool (A).

Tool number (A) : KV991J0090 (J-46214) (shown)  
 : KV101207S0 ( — )

↔ : Front

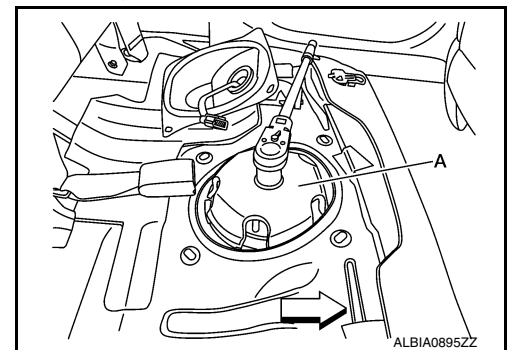

# FUEL LEVEL SENSOR UNIT, FUEL FILTER AND FUEL PUMP ASSEMBLY

## < REMOVAL AND INSTALLATION >

- After removal, observe the alignment between the fuel level sensor, fuel filter, and fuel pump assembly tabs (A) and the matching marks (C) on the fuel tank as shown. This alignment is necessary for proper installation.

(B) : Retainer mounting pawl

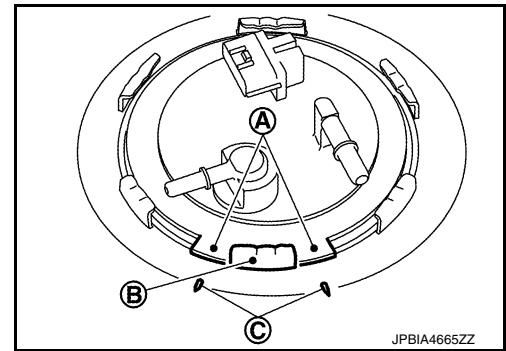

8. Remove the fuel level sensor, fuel filter, and fuel pump assembly (A). Remove and discard the O-ring.

### CAUTION:

- Do not bend the float arm during removal.
- Discard the O-ring. Do not reuse O-ring.

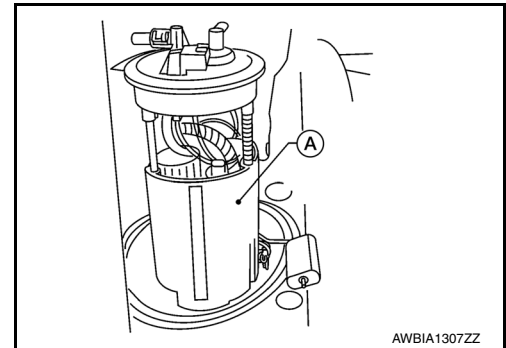

## INSTALLATION

Installation is in the reverse order of removal.

- Install the fuel level sensor, fuel filter, and fuel pump assembly with the fuel feed hose (B) facing the left side of the vehicle as shown. Use a new O-ring.

### CAUTION:

**Do not reuse O-ring.**

- ← :Front  
(A) EVAP hose  
(C) Harness connector

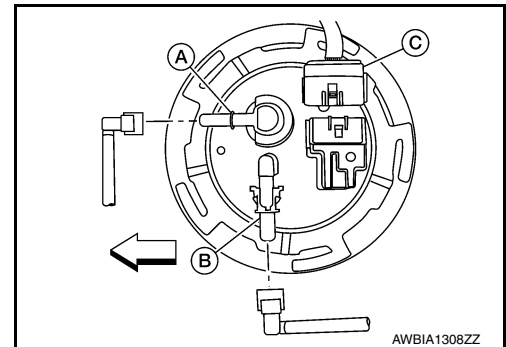

- Connect the quick connector as follows:
  - Check the connection for damage or any foreign materials.
  - Align the connector with the tube, then insert the connector straight into the tube until a click is heard.
  - After the tube is connected, make sure the connection is secure by performing the following checks:
    - Pull the tube and the connector to make sure they are securely connected.

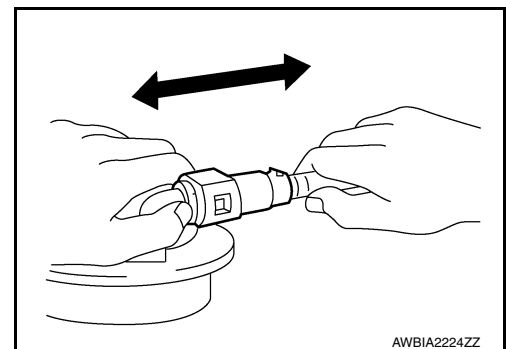



# FUEL LEVEL SENSOR UNIT, FUEL FILTER AND FUEL PUMP ASSEMBLY

## < REMOVAL AND INSTALLATION >

- Visually confirm that the two retainer tabs (3) are connected to the quick connector (2).

(1): Resin tube

(4): Retainer

(A): Connection (cross-section)

(B): Disconnection

(C): To under floor fuel line

(D): To fuel tank

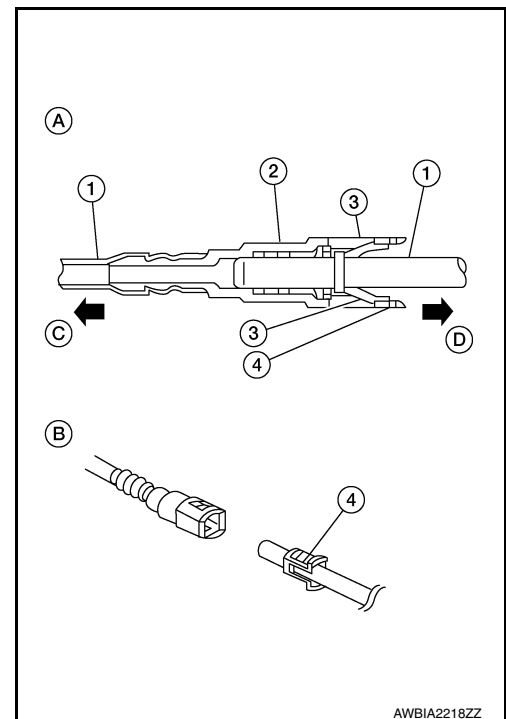

## Inspection

INFOID:0000000012260882

### INSPECTION AFTER INSTALLATION

Use the following procedure to check for fuel leaks:

1. Turn ignition switch "ON" (with engine stopped) then check connections for leaks by applying fuel pressure to fuel piping.
2. Start engine. Then let it idle and check that there are no fuel leaks at the fuel system connections.

# FUEL TANK

< REMOVAL AND INSTALLATION >

## FUEL TANK

### Exploded View

INFOID:000000011934772

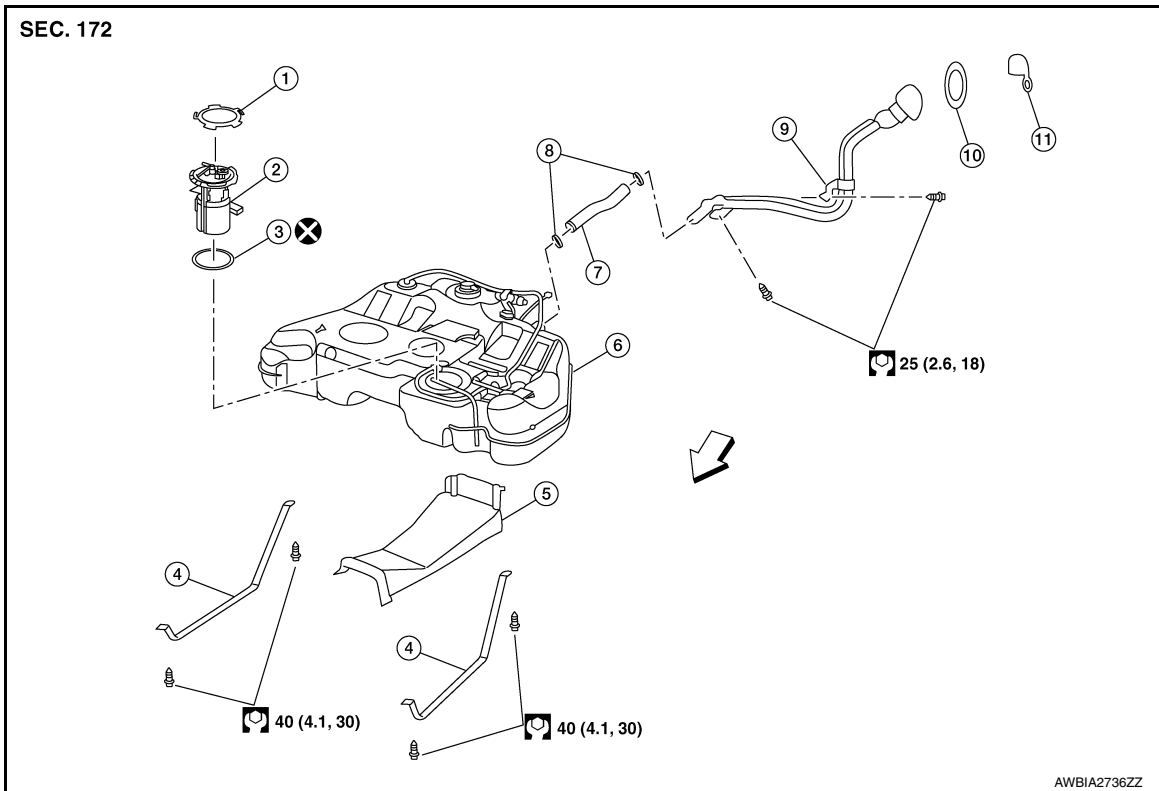

- |                              |  |                     |
|------------------------------|--|---------------------|
| 1. Lock ring                 | 2. Fuel level sensor unit, fuel filter, and fuel pump assembly | 3. O-ring           |
| 4. Fuel tank mounting straps | 5. Fuel tank protector   | 6. Fuel tank        |
| 7. Fuel filler hose          | 8. Clamp   | 9. Fuel filler hose |
| 10. Grommet                  | 11. Fuel filler cap  | ⇐ Front             |

### Removal and Installation

INFOID:000000011934773

#### **WARNING:**

Read "General Precautions" before working on the fuel system. Refer to [FL-2, "General Precaution"](#).

#### **CAUTION:**

If fuel tank is dropped while removing or installing, do not use.

#### **NOTE:**

When removing components such as hoses, tubes/lines, etc., cap or plug openings to prevent fluid from spilling.

#### REMOVAL

1. Check the fuel level with the vehicle on a level surface. If the fuel gauge indicates more than the level as shown (1/2 full), drain the fuel from the fuel tank until the fuel gauge indicates a level at or below as shown (1/2 full).
  - In case the fuel pump does not operate, use the following procedure.
- a. Insert fuel tubing of less than 25 mm (0.98 in) diameter into the fuel filler tube through the fuel filler opening to drain fuel from the fuel filler tube.
- b. Disconnect the fuel filler hose from the fuel filler tube.

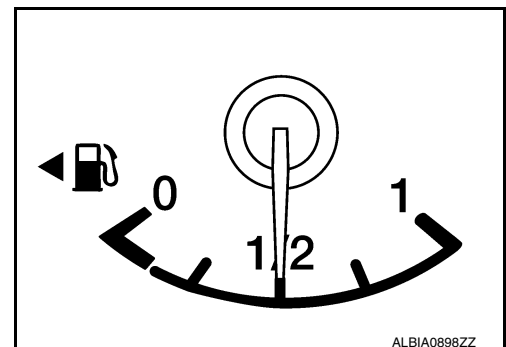

# FUEL TANK

## < REMOVAL AND INSTALLATION >

- c. Insert fuel tubing into the fuel tank through the fuel filler hose to drain fuel from the fuel tank.
  - As a guide, if the fuel tank is full the fuel level reaches or is less than the level on the fuel gauge as shown, when approximately 34 ℓ (9 US gal, 7 1/2 Imp gal) of fuel is drained from a full fuel tank.
2. Open the fuel filler cap to release the pressure inside the fuel tank.
3. Release fuel pressure from fuel line. Refer to [EC-164](#), "Work Procedure".
4. Disconnect the battery negative terminal. Refer to [PG-101](#), "Exploded View".
5. Remove rear seat cushion. Refer to [SE-89](#), "Removal and Installation".
6. Turn the four retainers (A) 90° in a clockwise direction and remove the fuel pump inspection hole cover.

↶ :Front

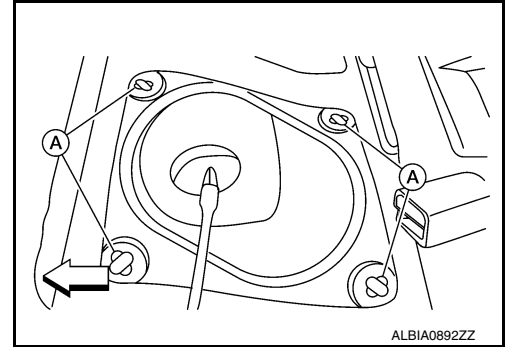

7. Disconnect the fuel level sensor, fuel filter, and fuel pump assembly harness connector (C), EVAP hose quick connector (A), and fuel feed hose (B) quick connector.

↶ :Front

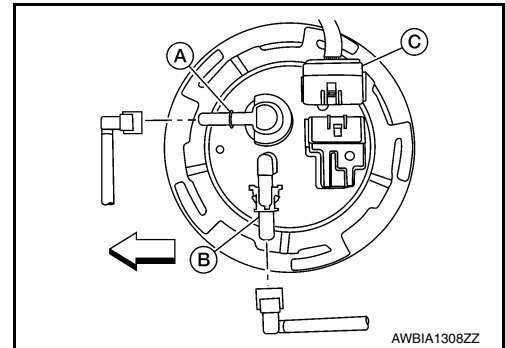

- a. Disconnect the quick connector as follows:
  - Hold the sides of the connector, push in tabs (A) and pull out the tube in the direction shown.
  - If the connector and the tube are stuck together, push and pull several times until they start to move. Then disconnect them by pulling in the direction shown.

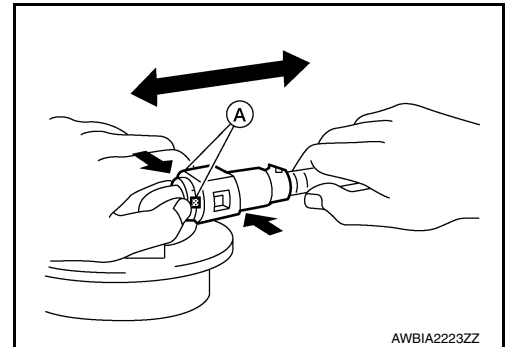

**CAUTION:**

# FUEL TANK

## < REMOVAL AND INSTALLATION >

- Quick connector (1) can be disconnected when the tabs (F) are depressed completely. Do not twist it more than necessary.

- (B) : Connection (cross-section)
- (D) : To under floor fuel line
- (E) : To fuel tank
- (G) : Disconnection

- Do not use any tools to disconnected quick connector.
- Keep resin tube (C) away from heat. Be especially careful when welding near the resin tube.
- Prevent acid liquid such as battery electrolyte, etc. from getting on resin tube.
- Do not bend or twist resin tube during installation and disconnection.
- Do not remove the remaining retainer (2) on hard tube (or the equivalent) (A) except when resin tube or retainer is replaced.
- When resin tube or hard tube (or the equivalent) is replaced, also replace retainer with new one.

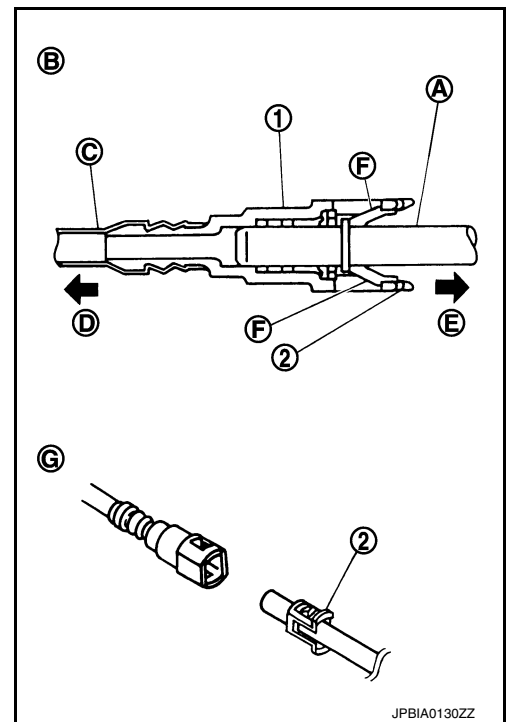

- To keep the connecting portion clean and to avoid damage and foreign materials, cover them completely with plastic bags (A) or something similar.

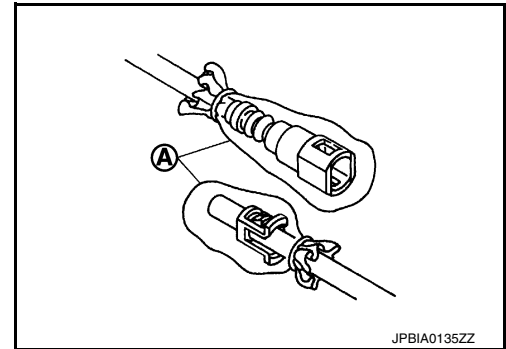

8. Remove rear wheel and tire using power tool. Refer to [WT-64, "Adjustment"](#).
9. Remove rear disc brake rotors. Refer to [BR-46, "DISC BRAKE ROTOR : Removal and Installation"](#).
10. Disconnect rear parking brake shoe, and remove rear cables from toggle lever. Refer to [PB-12, "Removal and Installation"](#).
11. Disconnect the 4 park brake rear cable mounting nuts (A) and position the rear park brake cables aside.

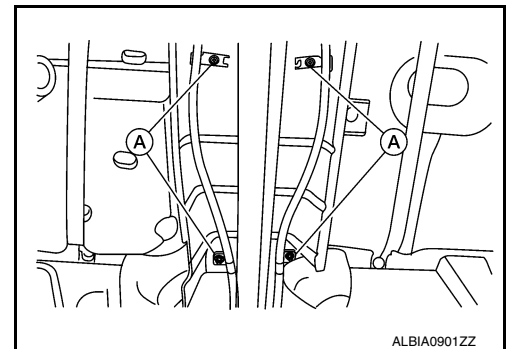

12. Remove the tunnel stay and center exhaust tube, without muffler(s). Refer to [EX-5, "Removal and Installation"](#).
13. Remove the fuel tank protector.
14. Disconnect the fuel filler hose and the recirculation hose at the fuel tank side.
15. Disconnect the EVAP line at the canister.

# FUEL TANK

## < REMOVAL AND INSTALLATION >

16. Remove the EVAP canister filter bracket mounting bolt and position EVAP canister filter and EVAP canister filter mounting bracket aside.
17. Disconnect the fuel tank mounting straps while supporting the fuel tank with a suitable jack.

**CAUTION:**

**Fuel tank may be in an unstable condition, due to the shape of the fuel tank bottom. Be sure to secure fuel tank at all times.**

18. Remove the fuel tank.
19. If replacing the fuel tank, remove the fuel level sensor, fuel filter and fuel pump assembly to transfer to the new fuel tank. Remove and discard the O-ring.

**CAUTION:**

- **Discard the O-ring. Do not reuse the O-ring.**
- **Do not bend float arm during removal and installation.**

## INSTALLATION

Installation is in the reverse order of removal.

- Connect the quick connector as follows:
  - Check the connection for damage or any foreign materials.
  - Align the connector with the tube, then insert the connector straight into the tube until a click is heard.
  - After the tube is connected, make sure the connection is secure by performing the following checks:
    - Pull the tube and the connector to make sure they are securely connected.

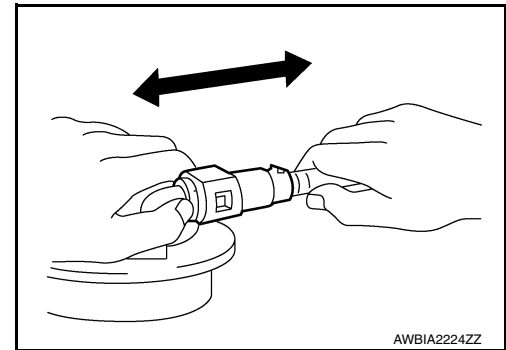

- Visually confirm that the two retainer tabs (3) are connected to the quick connector (2).

(1): Resin tube

(4): Retainer

(A): Connection (cross-section)

(B): Disconnection

(C): To under floor fuel line

(D): To fuel tank

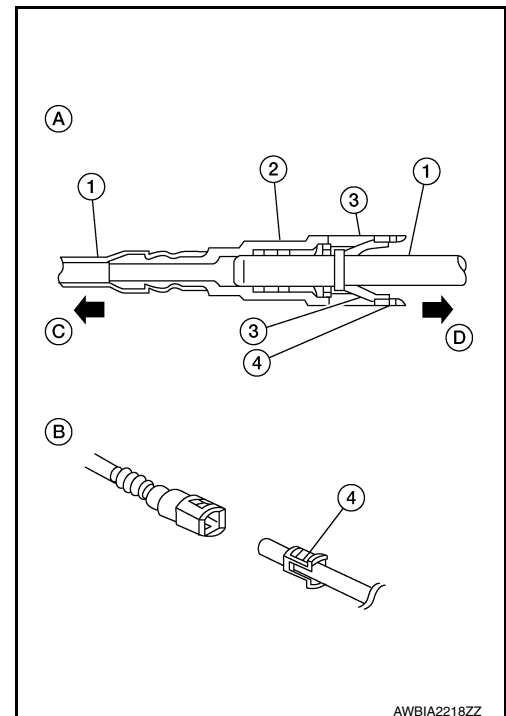

## Fuel Filler Hose

- Insert fuel filler hose to the length below:

**: 35 mm (1.38 in)**

- Be sure hose clamp is not placed on swollen area of fuel filler tube.

## FUEL TANK

### < REMOVAL AND INSTALLATION >

- Tighten the clamp hand with the top mark (A) until the mark is on the bolt head flange.

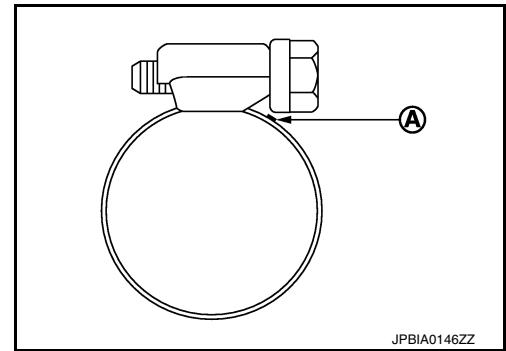

### Inspection

INFOID:000000012260887

#### INSPECTION AFTER INSTALLATION

Use the following procedure to check for fuel leaks:

1. Turn the ignition switch ON (without starting the engine). Then check the connections for fuel leaks by applying fuel pressure to the fuel piping.
2. Start engine, raise idle and verify there are no leaks at the fuel system connections.

# EVAP CANISTER

< REMOVAL AND INSTALLATION >

## EVAP CANISTER

Exploded View

INFOID:000000012250308

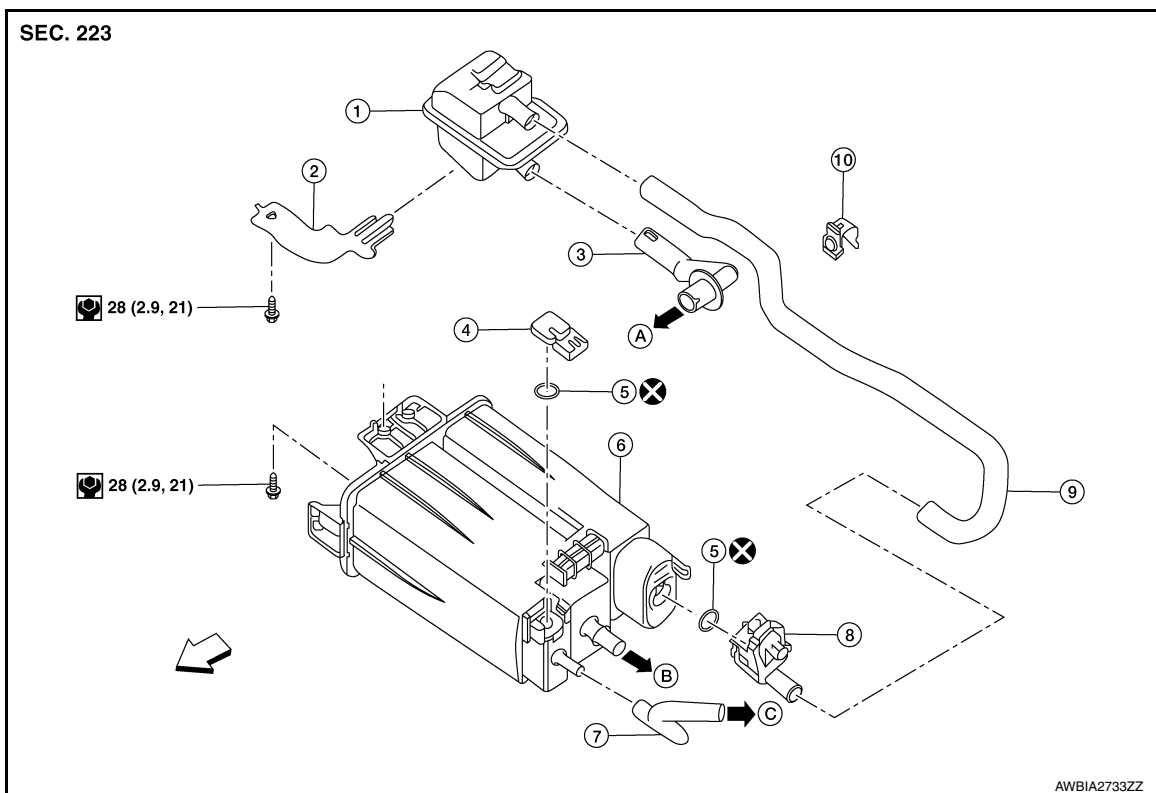

- |  |                                     |                                     |
|--|-------------------------------------|-------------------------------------|
| 1. EVAP canister filter                | 2. EVAP filter bracket              | 3. EVAP canister filter vent hose   |
| 4. EVAP control system pressure sensor | 5. O-ring                           | 6. EVAP canister                    |
| 7. EVAP canister purge hose            | 8. EVAP canister vent control valve | 9. EVAP canister control valve hose |
| 10. Clip                               | A. To vehicle body                  | B. To fuel tank                     |
| C. To EVAP tube                        | ↩ Front                             |                                     |

## Removal and Installation

INFOID:000000011934774

### NOTE:

The EVAP canister vent control valve and EVAP canister system pressure sensor can be removed without removing the EVAP canister.

### REMOVAL

1. Remove fuel tank. Refer to [FL-10, "Removal and Installation"](#).
2. Disconnect EVAP hose from EVAP canister.
3. Disconnect EVAP control system pressure sensor.
4. Disconnect EVAP canister vent control valve and hose.
5. Disconnect main EVAP hose from EVAP canister.
6. Remove EVAP canister bolt and EVAP canister.

### INSTALLATION

Installation is in the reverse order of removal.

### CAUTION:

**Do not reuse O-rings.**

### NOTE:

Tighten EVAP canister bolt to the specified torque.

# EVAP CANISTER

## < REMOVAL AND INSTALLATION >

### Inspection

INFOID:000000011934776

Check EVAP canister as per the following:

1. Block port (B).
2. Blow air into port (A) and check that it flows freely out of port (C).
3. Release blocked port (B).
4. Apply vacuum pressure to port (B) and check that vacuum pressure exists at the ports (A) and (C).
5. Block port (A) and (B).
6. Apply pressure to port (C) and check that there is no leakage.

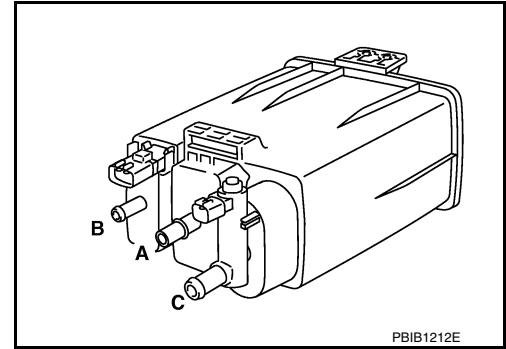



# EVAP CANISTER FILTER

< REMOVAL AND INSTALLATION >

## EVAP CANISTER FILTER

Exploded View

INFOID:000000012250311

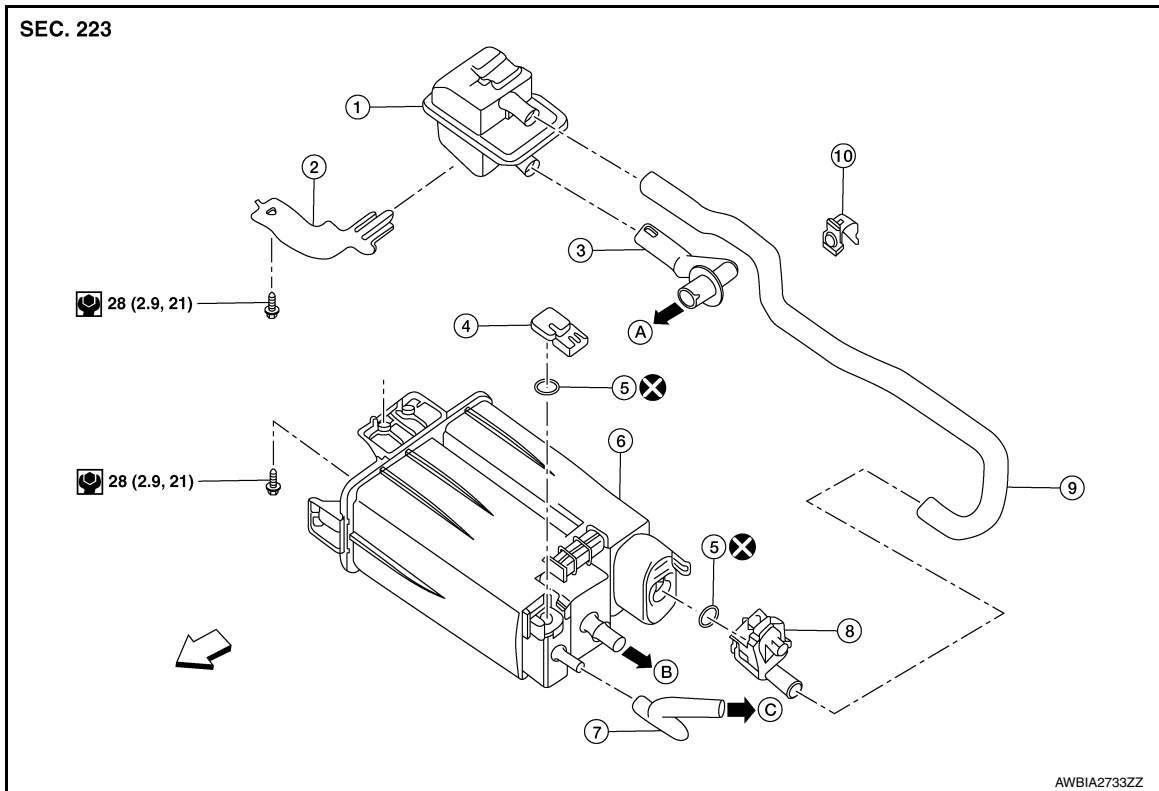

- |  |                                     |                                     |
|--|-------------------------------------|-------------------------------------|
| 1. EVAP canister filter                | 2. EVAP filter bracket              | 3. EVAP canister filter vent hose   |
| 4. EVAP control system pressure sensor | 5. O-ring                           | 6. EVAP canister                    |
| 7. EVAP canister purge hose            | 8. EVAP canister vent control valve | 9. EVAP canister control valve hose |
| 10. Clip                               | A. To vehicle body                  | B. To fuel tank                     |
| C. To EVAP tube                        | ← Front                             |                                     |

## Removal and Installation

INFOID:000000011934775

### REMOVAL

1. Disconnect the EVAP hose from the EVAP canister filter.
2. Remove the EVAP canister drain hose from the EVAP canister filter.
3. Remove EVAP canister filter.

### INSTALLATION

Installation is in the reverse order of removal.

# EVAP CANISTER VENT CONTROL VALVE

< REMOVAL AND INSTALLATION >

## EVAP CANISTER VENT CONTROL VALVE

Exploded View

INFOID:000000012462886

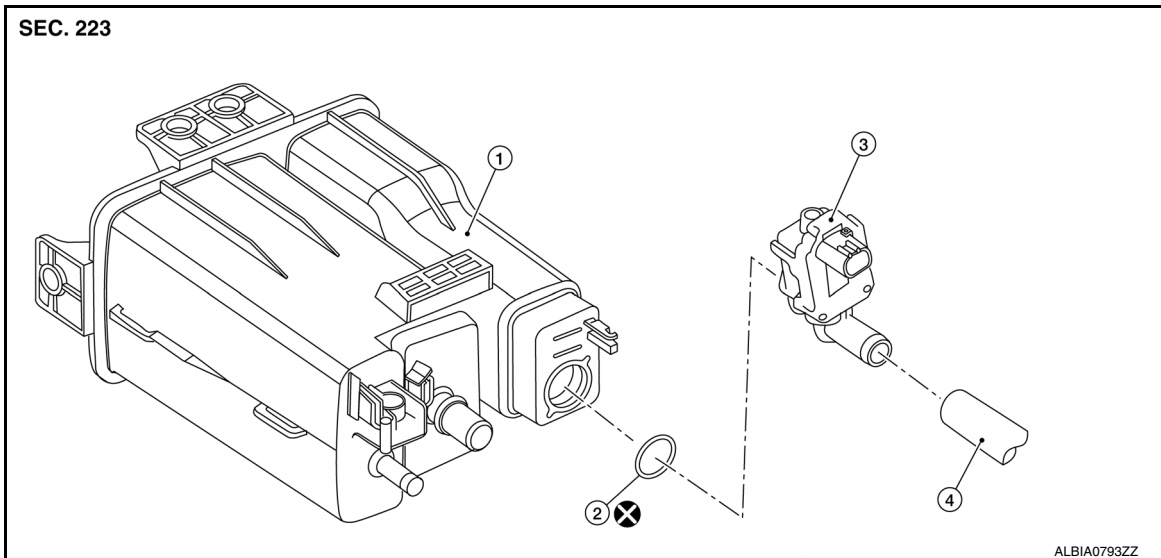

1. EVAP canister
2. O-ring
3. EVAP canister vent control valve
4. EVAP canister vent control valve hose

## Removal and Installation

INFOID:000000011934777

### REMOVAL

1. Disconnect the breather hose from the EVAP canister.
2. Disconnect the harness connector from the EVAP canister vent control valve.
3. Turn the EVAP canister vent control valve counterclockwise.

- (A) : Lock  
(B) : Unlock

4. Remove the EVAP canister vent control valve and O-ring.

**CAUTION:**  
Do not reuse O-ring.

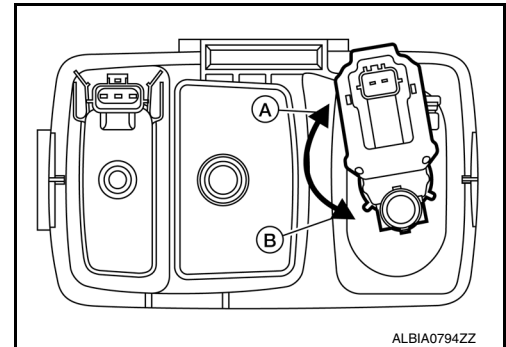

### INSTALLATION

Installation is in the reverse order of removal.

**CAUTION:**  
Do not reuse O-ring.

# EVAP CONTROL SYSTEM PRESSURE SENSOR

< REMOVAL AND INSTALLATION >

## EVAP CONTROL SYSTEM PRESSURE SENSOR

Exploded View

INFOID:000000012462867

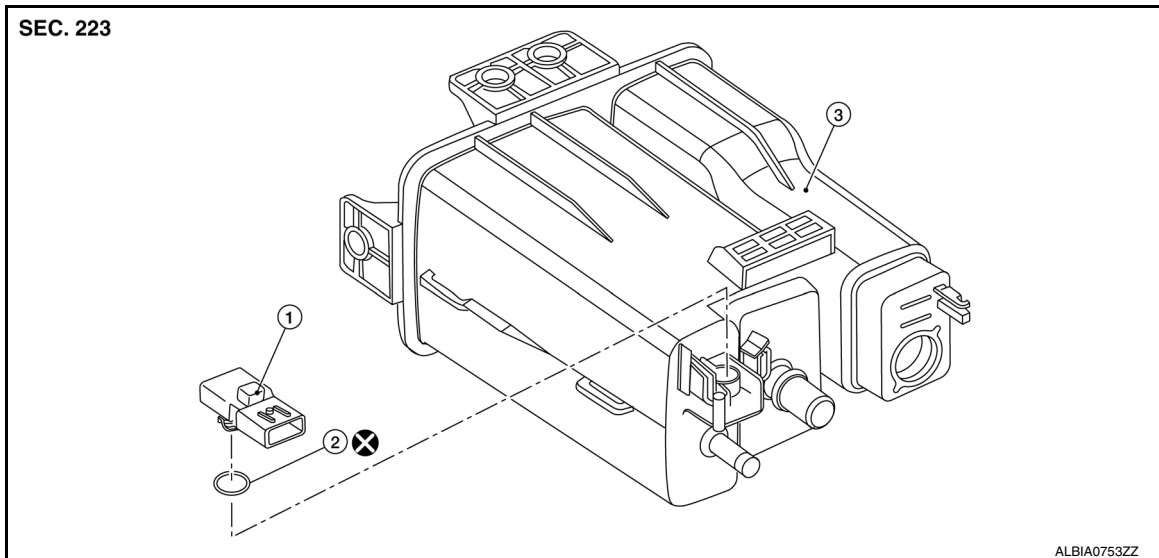

1. EVAP control system pressure sensor 2. O-ring 3. EVAP canister

### Removal and Installation

INFOID:000000011934778

#### REMOVAL

1. Disconnect the EVAP hose from the EVAP canister. Refer to [FL-15. "Exploded View"](#).
2. Disconnect the EVAP control system pressure sensor.
3. Remove the EVAP control system pressure sensor and O-ring.

**CAUTION:**

**Do not reuse O-ring.**

#### INSTALLATION

Installation is in the reverse order of removal.

**CAUTION:**

**Do not reuse O-ring.**

A  
FL  
C  
D  
E  
F  
G  
H  
I  
J  
K  
L  
M  
N  
O  
P

# FUEL LEVEL SENSOR UNIT

< DISASSEMBLY AND ASSEMBLY >

## DISASSEMBLY AND ASSEMBLY

### FUEL LEVEL SENSOR UNIT

Exploded View

INFOID:000000012269743

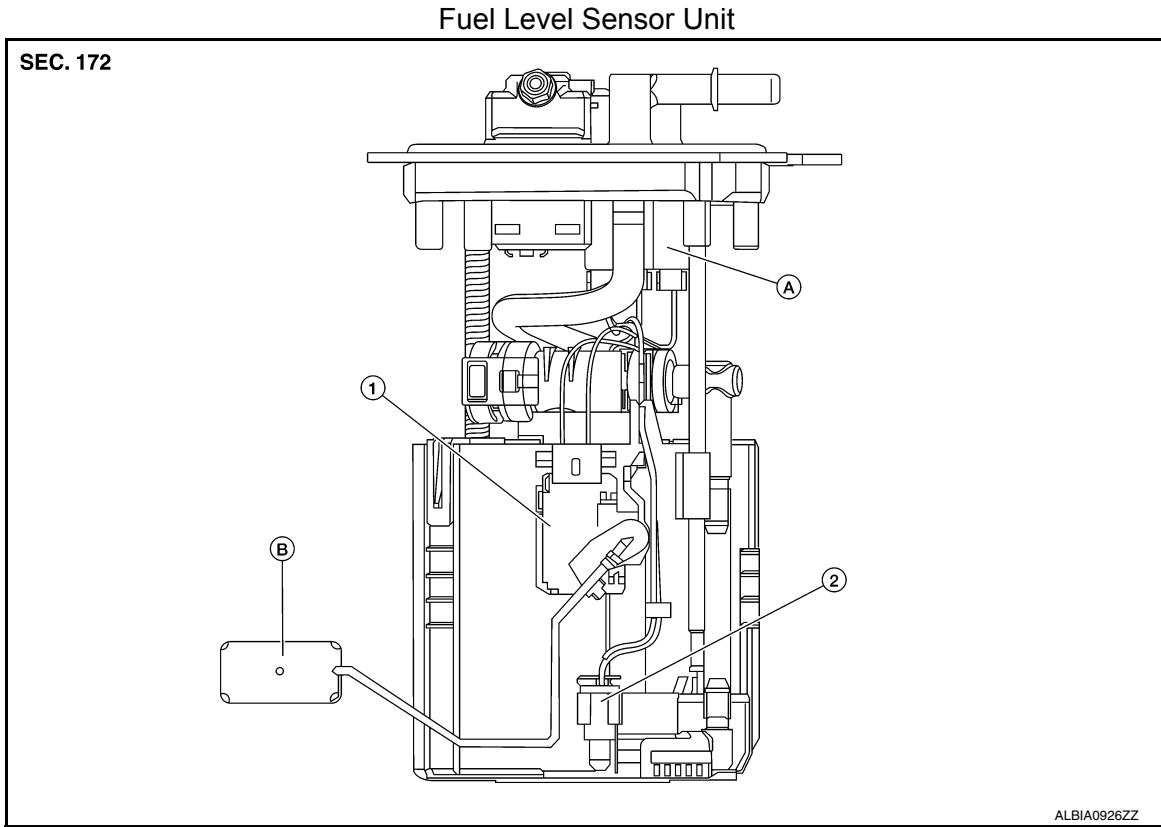

1. Level sensor unit module

2. Fuel temperature sensor

A. Harness connector

B. Float arm assembly

### Disassembly and Assembly

INFOID:000000011934779

#### Disassembly

##### NOTE:

Before disassembly, note the proper placement of the wires to the correct terminals and correct wire routing to the terminals.

1. Disconnect fuel level sensor unit (A) and fuel tank temperature sensor (C) harness connectors. Press the tabs on the terminals to release the locking tabs.

(B): Fuel pump harness connector

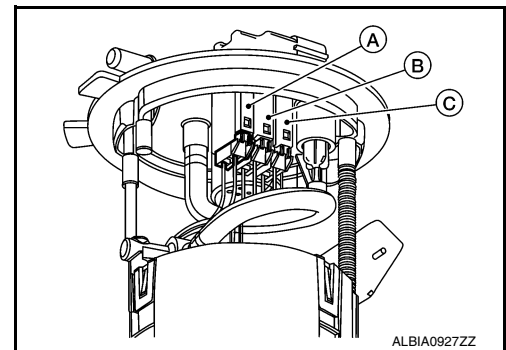

## FUEL LEVEL SENSOR UNIT

### < DISASSEMBLY AND ASSEMBLY >

2. Release the two clips and remove the fuel temperature sensor from the pump assembly.

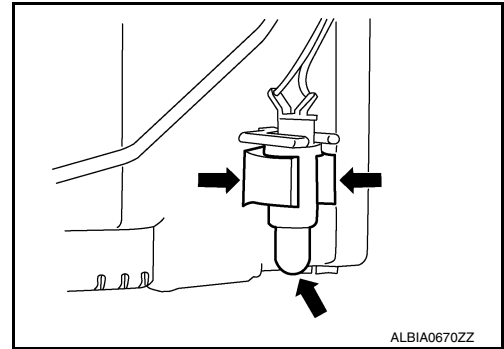

3. Release the tab (A) and slide the level sensor unit module and float arm assembly (B) up to remove.

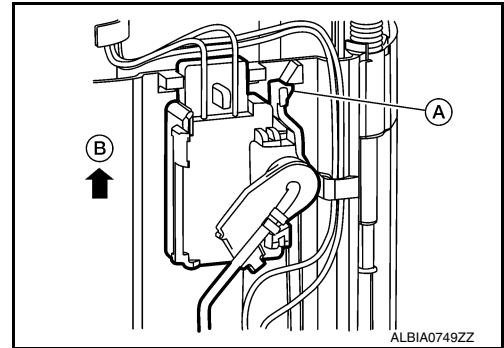

### Assembly

Assembly is the reverse order of disassembly.

#### NOTE:

- Ensure proper placement of the wires to the correct terminals and correct wire routing to the terminals.
- After connecting terminals, ensure they are securely locked and cannot be pulled out.
- When installing the level sensor unit, push down until the tab is locked into place.

## SERVICE DATA AND SPECIFICATIONS (SDS)

< SERVICE DATA AND SPECIFICATIONS (SDS)

# SERVICE DATA AND SPECIFICATIONS (SDS)

## SERVICE DATA AND SPECIFICATIONS (SDS)

### Fuel Tank

INFOID:0000000011934780

### Standard and Limit

Fuel tank capacity	Approx. 68 ℓ (18 US gal, 15 Imp gal)
Fuel recommendation	Refer to <a href="#">MA-16. "FOR USA AND CANADA : Fluids and Lubricants"</a> (United States and Canada), <a href="#">MA-17. "FOR MEXICO : Fluids and Lubricants"</a> (Mexico)